

EXP Technical Data High Lift Pallet Truck

[EXP 14](#)

[EXP 16](#)

[EXP 20](#)



EXP High Lift Pallet Truck

Flexibility meets innovation

This specification sheet, which conforms to VDI guideline 2198, provides the technical values for the standard equipment only. Different tyres, other masts, the use of accessories, etc. may result in other values.



Distinguishing marks			STILL	STILL	STILL			
			EXP 14	EXP 16	EXP 20			
1.1	Manufacturer							
1.2	Manufacturer's type designation							
1.3	Drive		Electric	Electric	Electric			
1.4	Operator type		Pedestrian	Pedestrian	Pedestrian			
1.5	Rated capacity/rated load	Q	kg	1400	1600	2000		
1.6	Load centre distance	c	mm	600	600	600		
1.8	Load distance, centre of drive axle to fork	x	mm	696 ^{1,3}	686 ^{1,3}	660 ^{1,3}		
1.9	Wheel base	y	mm	1406	1406	1406		
Weights	2.1	Service weight incl. battery		kg	1516	1556	1605	
	2.2	Axle loading, laden	drive end/load end	kg	1167/1749	1183/1972	1198/2406	
	2.3	Axle loading, unladen	drive end/load end	kg	1072/444	1086/470	1113/492	
Tyres/chassis	3.1	Tyres			Polyurethane	Polyurethane	Polyurethane	
	3.2	Tyre size	drive end	mm	Ø 230 x 90	Ø 230 x 90	Ø 230 x 90	
	3.3	Tyre size	load end	mm	Ø 85 x 85 (Ø 85 x 60) ²	Ø 85 x 85 (Ø 85 x 60) ²	Ø 85 x 85 (Ø 85 x 60) ²	
	3.4	Support castor size		mm	Ø 100 x 40	Ø 100 x 40	Ø 100 x 40	
	3.5	Number of wheels (x = driven)	drive end/load end		1x + 1/2 (1x + 1/4) ²	1x + 1/2 (1x + 1/4) ²	1x + 1/2 (1x + 1/4) ²	
	3.6	Tread	drive end	b ₁₀	mm	534	534	534
	3.7	Tread	load end	b ₁₁	mm	1000/1200/1400	1000/1200/1400	1000/1200/1400
Dimensions	4.2	Height	mast lowered	h ₁	mm	see mast table	see mast table	see mast table
	4.3	Free lift		h ₂	mm	see mast table	see mast table	see mast table
	4.4	Lift		h ₃	mm	see mast table	see mast table	see mast table
	4.5	Height	mast extended	h ₄	mm	see mast table	see mast table	see mast table
	4.9	Height drawbar in driving position	min./max.	h ₁₄	mm	800/1250	800/1250	800/1250
	4.10	Height of wheel arms		h ₈	mm	80	80	80
	4.15	Fork height, lowered		h ₁₃	mm	50	55	55
	4.19	Overall length		l ₁	mm	2071	2081	2107
	4.20	Length to face of forks		l ₂	mm	921 ^{3,4}	931 ^{3,4}	957 ^{3,4}
	4.21	Overall width		b ₁	mm	1170/1370/1570	1170/1370/1570	1170/1370/1570
	4.22	Fork dimensions		s/e/l	mm	35/100/1150	45/120/1150	45/120/1150
	4.24	Fork carriage width		b ₃	mm	820/980	820/980	820/980
	4.25	Distance between fork arms	min./max.	b ₅	mm	400/720 // 400/880	420/740 // 420/900	420/740 // 420/900
	4.26	Distance between wheel arms		b ₄	mm	860/1060/1260	860/1060/1260	860/1060/1260
	4.32	Ground clearance, centre of the wheel base		m ₂	mm	30	30	30
4.33	Aisle with for pallets 1000 x 1200 crossways		A _{st}	mm	2588 ⁴	2592 ⁴	2605 ⁴	
4.34	Aisle with for pallets 800 x 1200 lengthways		A _{st}	mm	2559 ⁴	2566 ⁴	2587 ⁴	
4.35	Turning radius		W _a	mm	1715 ⁴	1715 ⁴	1715 ⁴	
Performance data	5.1	Travel speed	laden/unladen	km/h	6/6	6/6	6/6	
	5.2	Lift speed	laden/unladen	m/s	0.16/0.30	0.15/0.30	0.15/0.30	
	5.3	Lowering speed	laden/unladen	m/s	0.40/0.35	0.40/0.35	0.31/0.31	
	5.8	Max. gradeability kB 5	laden/unladen	%	8/8	8/8	8/8	
5.10	Service brake				Electromagnetic	Electromagnetic	Electromagnetic	
Electric engine	6.1	Drive motor, rating S2 = 60 min		kW	2.3	2.3	2.3	
	6.2	Lift motor, rating at S3 = 15%		kW	3.2	3.2	3.2	
	6.3	Battery according to DIN 43531/35/36 A, B, C, no			3PzS	3PzS	3PzS	
	6.4	Battery voltage/rated capacity K ₅		V/Ah	24/345	24/345	24/345	
	6.5	Battery weight (±5%, depends on make)		kg	288	288	288	
Misc.	8.1	Drive control			AC control	AC control	AC control	
	8.4	Sound pressure level at driver's ear		dB(A)	≤66	≤66	≤66	

¹ With Tele and HiLo mast +26 mm

² With tandem rollers

³ Value with Triplex mast h₁ = 1915 mm

⁴ Without creep speed +12 mm

EXP High Lift Pallet Truck Mast Tables



		Tele								HiLo				Triplex							
EXP 14	Height	h_1	mm	1415 ¹	1665 ¹	1915	2115	2365	2565	2815	1415 ¹	1665 ¹	1915	2115	2365	2565	1665 ¹	1915	2065	2265	2315
	Mast height with used initial lift	h_1'	mm	1490	1740	1990	2190	2440	2640	2890	-	-	-	-	-	-	-	-	-	-	-
	Free lift	h_2^2	mm	-	-	-	-	-	-	-	776	1026	1276	1476	1726	1926	1026	1276	1426	1626	1676
	Free lift	h_2^3	mm	150	150	150	150	150	150	150	-	-	-	-	-	-	-	-	-	-	-
	Lift	h_3	mm	1844	2344	2844	3244	3744	4144	4644	1844	2344	2844	3244	3744	4144	3516	4266	4716	5316	5466
	Height mast extended	h_4^4	mm	2480	2980	3480	3880	4380	4780	5280	2480	2980	3480	3880	4380	4780	4152	4902	5352	5952	6102
		Tele								HiLo				Triplex							
EXP 16	Height	h_1	mm	1415 ¹	1665 ¹	1915	2115	2365	2565	2815	1415 ¹	1665 ¹	1915	2115	2365	2565	1665 ¹	1915	2065	2265	2315
	Mast height with used initial lift	h_1'	mm	1490	1740	1990	2190	2440	2640	2890	-	-	-	-	-	-	-	-	-	-	-
	Free lift	h_2^2	mm	-	-	-	-	-	-	-	786	1036	1286	1486	1736	1936	1036	1286	1436	1636	1686
	Free lift	h_2^3	mm	150	150	150	150	150	150	150	-	-	-	-	-	-	-	-	-	-	-
	Lift	h_3	mm	1844	2344	2844	3244	3744	4144	4644	1844	2344	2844	3244	3744	4144	3516	4266	4716	5316	5466
	Height mast extended	h_4^4	mm	2470	2970	3470	3870	4370	4770	5270	2470	2970	3470	3870	4370	4770	4142	4892	5342	5942	6092
		Tele				HiLo				Triplex											
EXP 20	Height	h_1	mm	1915	2115	2365	1915	2115	2365	1665 ¹	1915	2065									
	Mast height with used initial lift	h_1'	mm	1990	2190	2440	-	-	-	-	-	-									
	Free lift	h_2^2	mm	-	-	-	1286	1486	1736	1036	1286	1436									
	Free lift	h_2^3	mm	150	150	150	-	-	-	-	-	-									
	Lift	h_3	mm	2684	3084	3584	2684	3084	3584	3276	4026	4476									
	Height mast extended	h_4^4	mm	3310	3710	4210	3310	3710	4210	3902	4652	5102									

¹ Mast not recommended with daily battery change

² With load backrest - 537 mm

³ With increased height mast h_1'

⁴ With load backrest + 537 mm

Technical Drawings

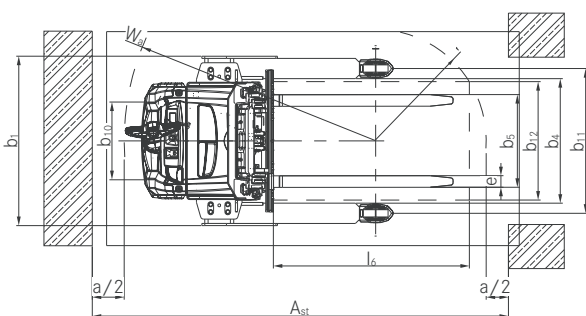

Top view

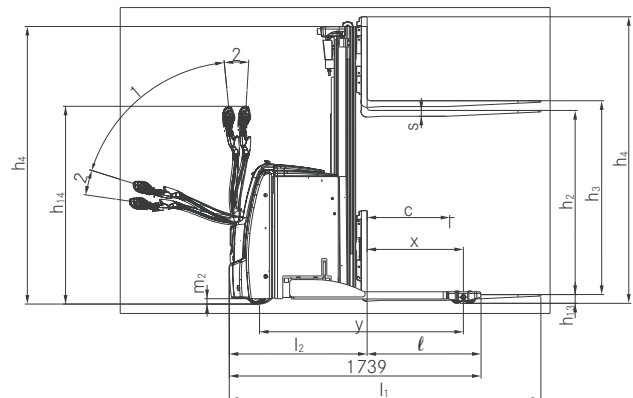

Side view

EXP High Lift Pallet Truck Detailed Photos



Safety in production: depending on tiller angle, speed is automatically adapted to the distance between the operator and the truck



High availability: compact, robust frame design ensures durability



Everything in view, all the time: colour display with a range of language-independent symbols shows you all of the important functions at a glance



Precise in all situations: creep speed also makes it possible to manoeuvre in the most confined of spaces



STILL free view mast always ensures the best view of the tips of the forks



All-rounder: self-supporting and adjustable forks allow the handling of different pallet types

EXP High Lift Pallet Truck
Flexibility meets innovation



EXP High Lift Pallet Truck

Flexibility meets innovation

Highest flexibility: different pallet types and accessory equipment usable

Optimum utilisation of storage area: high storage compaction due to very high residual load capacity

Everything in view, all the time: colour display with a range of language-independent symbols shows you all of the important functions at a glance



Stronger and more intelligent than the rest – that's the STILL EXP 14-20 high lift pallet truck. Two of its stand-out features are its huge residual load capacity and its smart colour display. The latter provides the operator with basic information, the truck status or the battery's state of charge at a glance at all times, and different language-independent symbols provide optimum support in operation. The smart and extremely mobile warehouse organiser moves pallets weighing up to 2,000 kg quickly, safely and reliably. Through self-supporting and adjustable forks different pallets can be used. With optional hydraulic functions accessory equipment can be used as well. It can achieve unprecedented reloading of pallets thanks to its

powerful and low-maintenance motor and its precise control elements, which are suitable for either left- or right-handed operators. The letters EXP are not, however, just synonymous with quick goods handling, but also with safe goods handling. The optional load capacity display shows what is possible. The curved tiller shape and the sensitive impact plate protect the driver, and the EXP stops automatically when the tiller is released – even on ramps. The OPTISPEED tiller also adjusts the speed of the EXP to the distance from the operator, while the Curve Speed Control system regulates the speed around bends. This high lift pallet truck, which is as strong as it is smart, allows you to always keep your flow of goods safely under control; from transporting loads within the pre-storage area to operating the shelving system.

Extensive Equipment

Power

- All-rounder: self-supporting and adjustable forks allow the handling of different pallet types
- Optimal utilisation of storage space: high storage compaction due to very high residual load capacity
- High reloading performance: powerful, reliable and low-maintenance electrical drive and steering motor
- The right driving programme for all situations: Select maximum turnaround or maximum efficiency: ECO, BOOST or Blue-Q

Precision

- Fatigue-free operation: precise and intuitive electrical steering unit
- Precise operation even in the most confined spaces: sensitive proportional valve control and optional creep speed function
- Best views for precise operation: free view mast and centrally mounted tiller ensure clear view of the tips of the forks

Ergonomics

- High flexibility: up to two additional hydraulic functions for the use of accessory equipment
- Ergonomic and intuitive operation: driving, lifting and steering processes can be simultaneously controlled by left- or right-handed operators using just one hand
- Easing of workload: easy to operate, ergonomically shaped STILL tiller head

Compactness

- Impressive reloading of pallets: compact size allows for quick and safe operation
- Additional storage space for goods: copes with narrow aisles thanks to its compact dimensions and high manoeuvrability

Safety

- Safety in production: OPTISPEED tiller adapts speed automatically depending on distance between the operator and the truck
- Safety in mind: optional load capacity display shows the operator the current mast height and associated residual load capacity at all times
- Safe around corners: Curve Speed Control automatically adapts the speed when cornering to the steering angle

Environmental Responsibility

- Blue-Q efficiency mode allows energy savings of up to 7 per cent at the press of a button with no loss of performance
- Very few noise emissions due to extremely quiet drive and lifting motor
- Over 95 percent of all materials used are recyclable
- ECO driving programme: maximum energy efficiency at the touch of a button

EXP High Lift Pallet Truck Equipment Variants



	EXP 14	EXP 16	EXP 20	
General	Display and operating unit with colour display for selection of driving programme	●	●	●
	Integrated storage facilities	●	●	●
	Straddle forks for picking up closed pallets	●	●	●
	Easy-grip tiller for left and right-handed operators	●	●	●
	Two-stage setting option for high-precision lifting and lowering	●	●	●
	Blue-Q energy-saving mode	●	●	●
	Forks ISO 2B	●	●	●
	Accessory bar	○	○	—
	Electric preparation for data terminal	○	○	○
	Cold storage version	○	○	○
	High-performance rotary driving motor has very low maintenance costs	●	●	●
	Electrical steering unit: AC steering motor for exceptionally fatigue-free operation	●	●	●
	Proportional valve technology for high-precision movements	●	●	●
	Up to two additional hydraulic functions for the use of accessory equipment	○	○	○
Mast	Telescopic mast	○	○	○
	HiLo mast	○	○	○
	Triplex mast	○	○	○
	Mast protective grille	●	●	●
	Protective mast screen made from polycarbonate	○	○	○
	Load capacity display	○	○	○
Wheels	Drive wheel tyres, polyurethane	●	●	●
	Drive wheel tyres, polyurethane (75 Shore) for better traction	○	○	○
	Drive wheel tyres, polyurethane, profiled (75 Shore) for better traction	○	○	○
	Drive wheel tyres, solid rubber	○	○	○
	Drive wheel tyres, solid rubber, profiled	○	○	○
	Drive wheel tyres, solid rubber, natural-coloured	○	○	○
	Load roller tyres, polyurethane, single	●	●	●
	Load roller tyres, polyurethane, tandem	○	○	○
	Fully enclosed components which are impervious to dirt and dust	●	●	●
Safety	Stabilising wheel, single	●	●	●
	FleetManager: access authorisation, shock detection, reports	○	○	○
	Curve Speed Control: reduction when driving around corners	●	●	●
	OPTISPEED tiller: maximum driving speed controlled by the tiller angle	●	●	●
	Vertical tiller creep speed button with lift/lowering	○	○	○
	Access authorisation with STILL key	●	●	●
Battery	PIN code access	○	○	○
	Load backrest	○	○	○
	Battery compartment for battery up to 375 Ah for battery replacement using crane	●	●	●
Built-in charger	○	○	○	

● Standard ○ Optional — Not available

STILL



STILL Materials Handling Ltd
Aston Way
Leyland Preston
PR26 7UX
Tel.: +44 (0)845 603 6827

STILL Materials Handling Ltd
Jacks Way
Hill Barton
Business Park
Clyst St. Mary
Exeter
EX5 1FG
Tel.: +44 (0)345 603 6827

info@still.co.uk

For further information please visit:

www.still.co.uk



STILL is certified in the following areas: Quality management, occupational safety, environmental protection and energy management.



first in intralogistics